

# POWERBAR

BY

RIGGING GEAR SALES, INC.

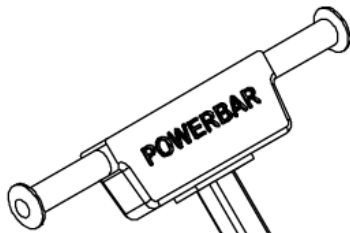

## **COST EFFECTIVE**

By reducing personnel required for load movement, as well as maintenance and material handling costs.

## **EASY TO OPERATE**

Allowing a single person to skid loads up to 4 tons.

## **POWERFUL**

Pushing power equivalent to a 15,000 lbs. forklift in a compact package.

## **MANEUVERABLE**

Its slender design makes handling problems in space restricted areas quick and easy.

## **ADAPTABLE**

The POWERBAR can be combined with most machinery moving dollies for precise movement of the heaviest loads.

## **LOW MAINTENANCE**

Virtually no preventative maintenance is required.

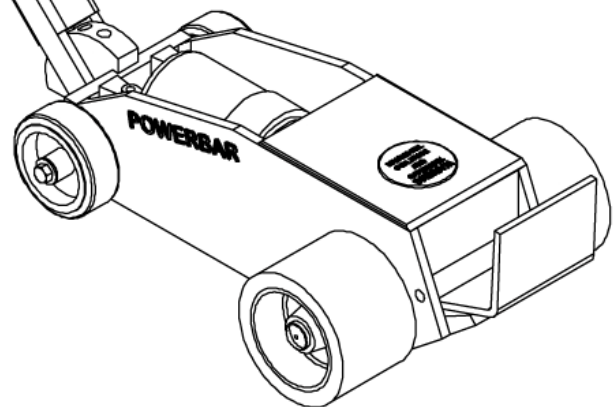

**RIGGING GEAR SALES, INC.**  
**P.O. BOX 544**  
**1555 IL ROUTE 26 SOUTH**  
**DIXON, IL 61021**

**PHONE: +1-815-288-6403**  
**FAX: +1-815-288-6100**  
**EMAIL: info@rgsinc.net**  
**WEB: www.rgsinc.net**

# POWERBAR

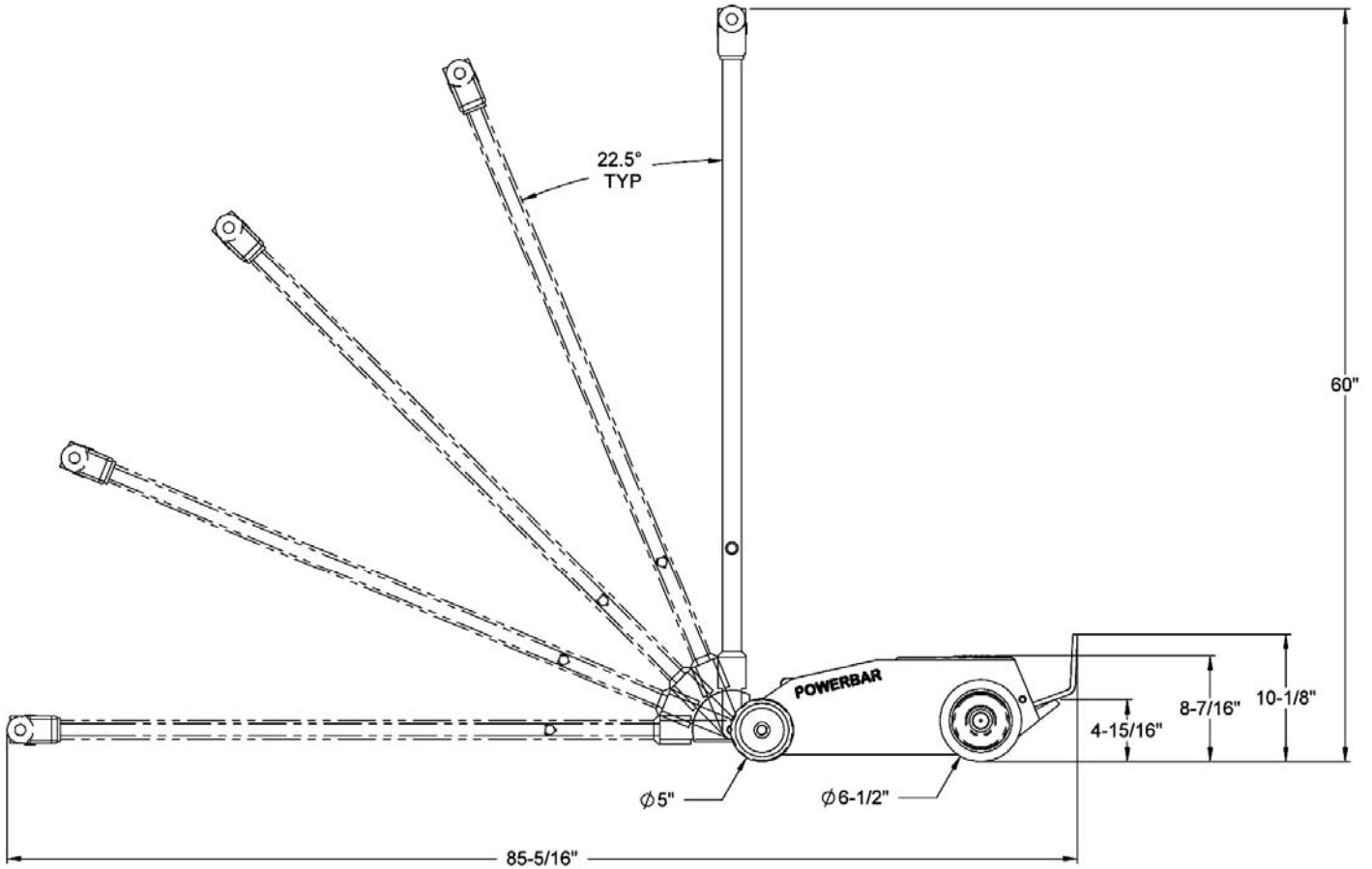
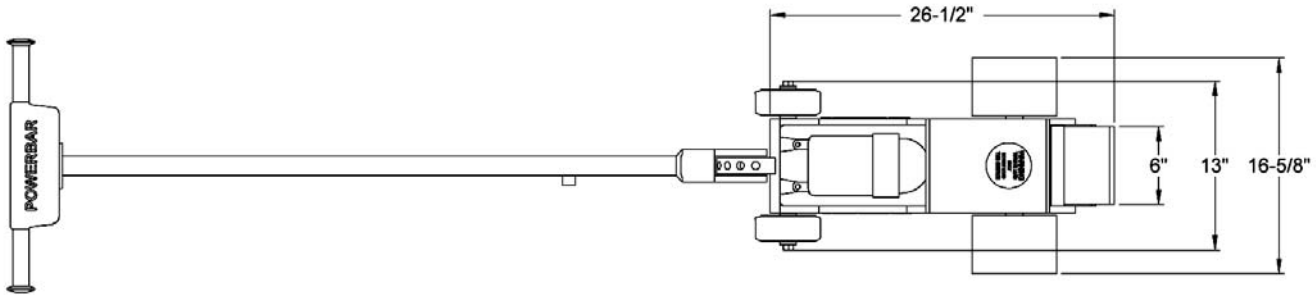

## TECHNICAL DATA/SPECIFICATIONS

Rated Capacity.....Skid 8,000 lbs.  
 Weight of Unit.....125 lbs.  
 Free Running Speed.....38.5 ft./min.

## DRIVE WHEEL

Size.....6.5" dia. 4.5" wide  
 Composition.....Polyurethane

## MOTOR CHARACTERISTICS

Motor Rating Continuous....1/2 Horsepower  
 Current Free Running.....5 amp  
 Current Stall.....30 amp  
 Voltage.....115v AC

**Distributed By:**