



# MODEL 34PT5400WT

## 500 Ton POWER TOWER Gantry System

### CAPACITY:

#### 4 Point

500 (450) Tons to 27'6" (8,382 mm)  
400 (360) Tons to 35' (10,668 mm)

#### 2 Point

250 (225) Tons to 27'6" (8,382 mm)  
200 (181) Tons to 35' (10,668 mm)

Max. Operating PSI: 2750 (190 bar)

### BASE DIMENSIONS:

Length: 91.5" (2324 mm)  
Width: 48" (1219 mm)  
Height Retracted: 11'6" (3505 mm)  
Weight: 16,220 lbs. (7364 kg)

### POWER UNITS:

Two (2) 300 gallon (1136 L) Power Units  
per Four Point System

Power Options: Diesel, Gasoline,  
Propane, Electric (3 phase, 440 Volt,  
60 Hz; or 3 Phase, 380 Volt, 50Hz)

Length: 92.5" (2350 mm)  
Width: 61.5" (1562 mm)  
Height: 61" (1549 mm)  
Weight: 5250 lbs. (2384 kg)

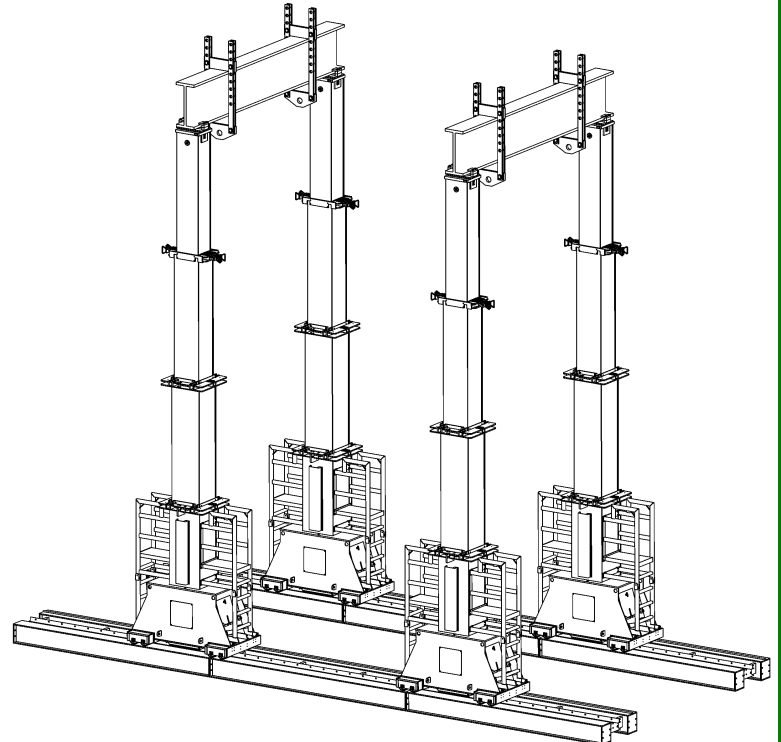

### STANDARD FEATURES

- Straightest Booms in the Industry
- Large Lift Lugs
- Safety Holding Valves
- Wedge Inter-Lock System
- Large Work Platforms
- Double Acting Cylinders

### LIFT SYSTEMS, INC.

OFFICE:  
1505 - 7th Street  
East Moline, IL 61244

MAILING ADDRESS:  
P.O. Box 906  
Moline, IL 61266

TEL: +1-309-764-9842  
FAX: +1-309-764-9848  
EMAIL: [liftit@lift-systems.com](mailto:liftit@lift-systems.com)  
WEB: [www.lift-systems.com](http://www.lift-systems.com)

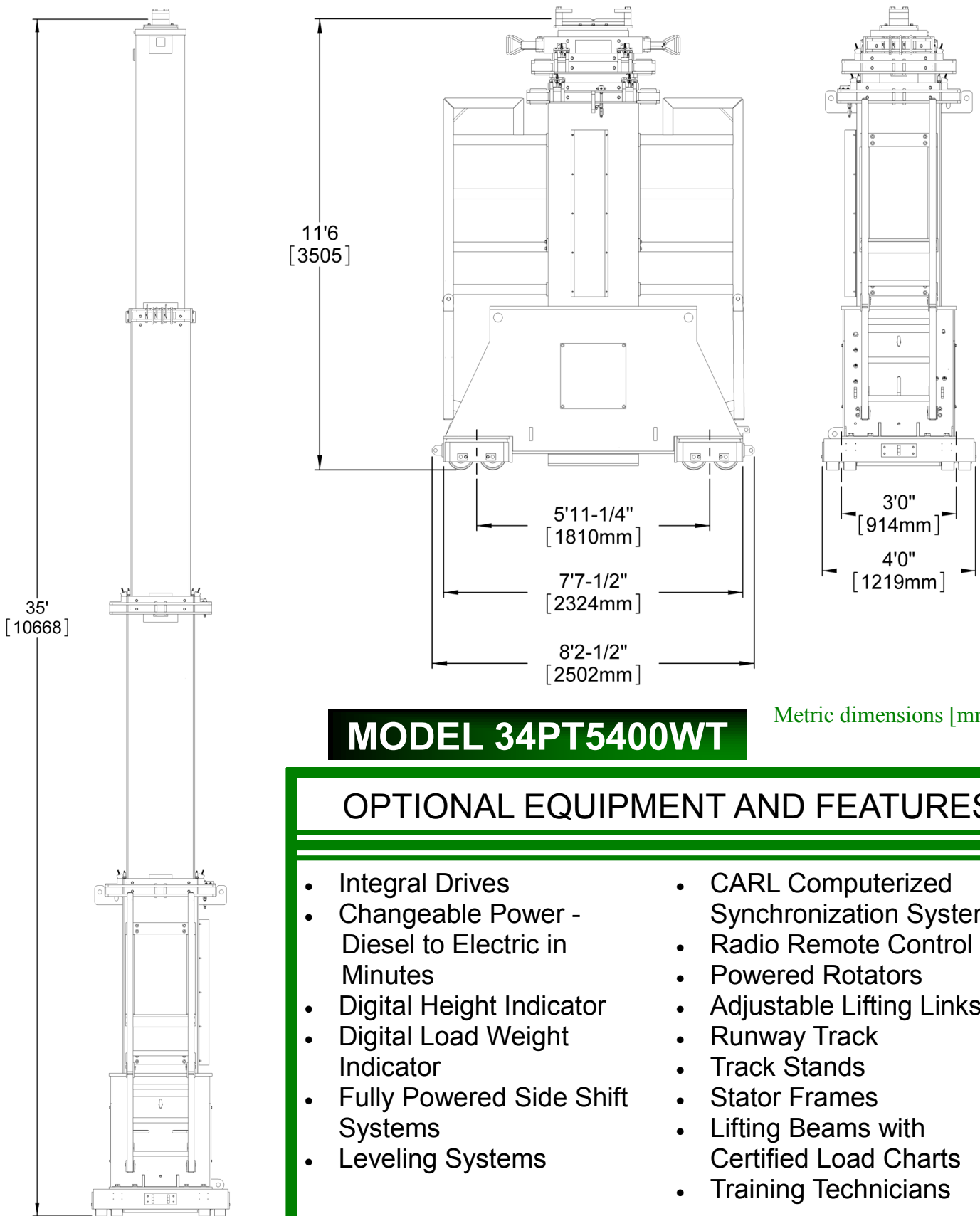

## MODEL 34PT5400WT

Metric dimensions [mm]

### OPTIONAL EQUIPMENT AND FEATURES

- Integral Drives
- Changeable Power - Diesel to Electric in Minutes
- Digital Height Indicator
- Digital Load Weight Indicator
- Fully Powered Side Shift Systems
- Leveling Systems
- CARL Computerized Synchronization System
- Radio Remote Control
- Powered Rotators
- Adjustable Lifting Links
- Runway Track
- Track Stands
- Stator Frames
- Lifting Beams with Certified Load Charts
- Training Technicians

## LIFT SYSTEMS, INC.

OFFICE:  
1505 - 7th Street  
East Moline, IL 61244

MAILING ADDRESS:  
P.O. Box 906  
Moline, IL 61266

TEL: +1-309-764-9842  
FAX: +1-309-764-9848  
EMAIL: [liftit@lift-systems.com](mailto:liftit@lift-systems.com)  
WEB: [www.lift-systems.com](http://www.lift-systems.com)